

TBi MOG 70 Welding Torch for self-shielded flux cored wires

for wires up to 3.2 mm

easily rotatable and exchangeable necks

attractively priced consumables

Ordering information

TBi MOG 70	cable assembly w/o torch neck, Euro-connector	111P1423_0*
TBi MOG 70 Z	as above, with addtl. rocker switch	111P1223_0*

Please order the required torch neck and consumables separately according to the part list on page 2.

* At the blank, please insert 3, 4 or 5 for a torch length of 3, 4 or 5 m.

Technische Daten

Handheld welding torch TBi MOG 70

Rating at 60% duty cycle (10 min. cycle)	430 A
Cooling method	air cooled
Wire diameter	1.6 – 3.2 mm
Technical specification	according to IEC 60974-7
Weight with 1.5m cable	2.50 kg
Connection	Euro-Central connector, other connectors (e.g. CLOOS®, ESAB®, Lincoln®) available upon request.

Torch rating will be reduced when using pulsed-arc power sources. Special torch necks and custom lengths of the coaxial cable are available upon request.

100

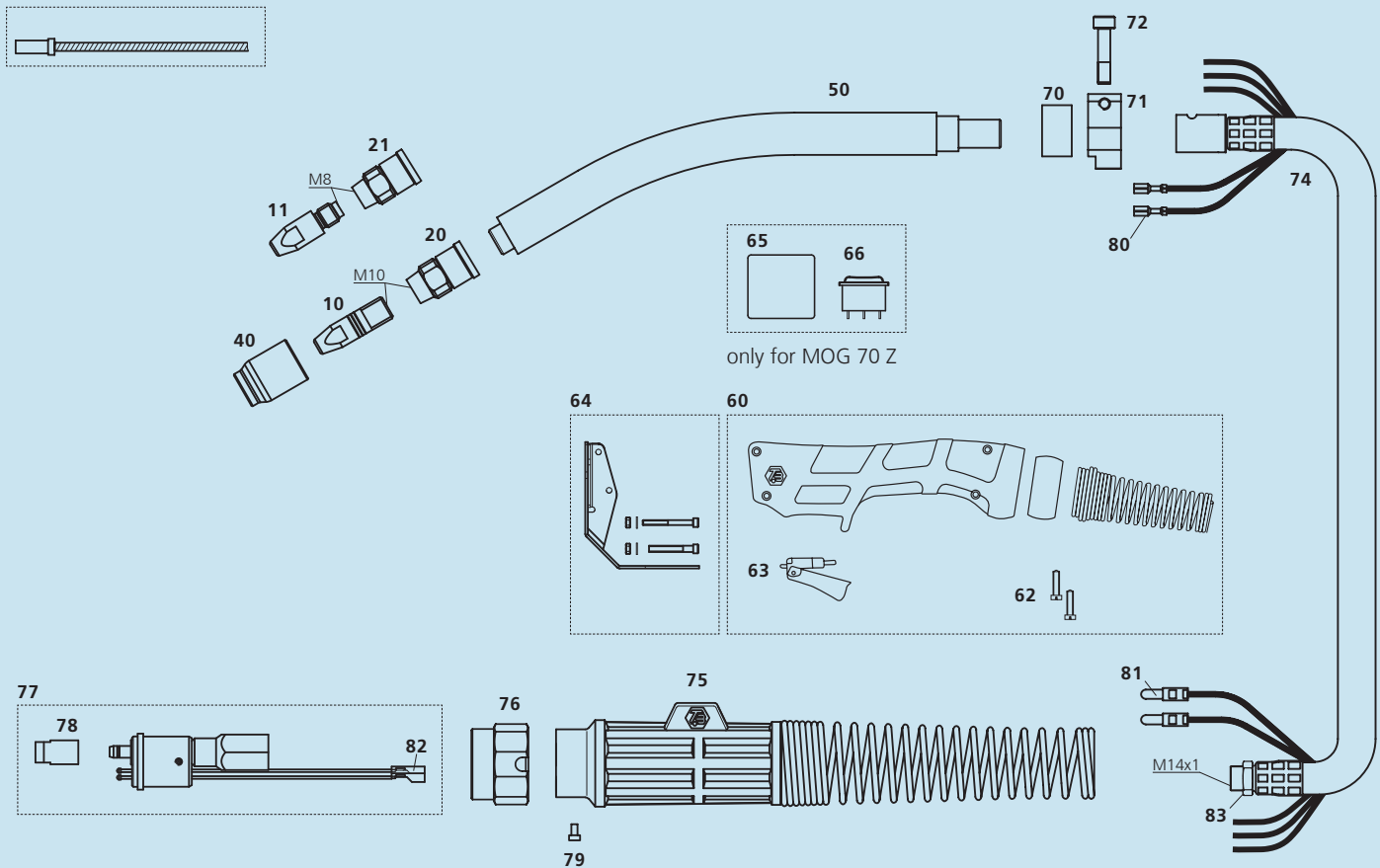

Pos.	Description	Part. No.	Pos.	Description	Part. No.
Contact tips					
10	Contact tip M8x30, ECu	340P__1262*	76	Adaptor nut	701P001013
▶ 10	Contact tip M8x30, CuCrZr	340P__3262*	77	Euro connector RGZ, for MOG	701P101014
11	Contact tip M10x33, ECu	340P__1402*	78	Centering bolt M14x1 RGZ / RWZ	701P002083
11	Contact tip M10x33, CuCrZr	343P__3402*	79	Slotted screw M4x6	100P008401
Düsenstöcke					
▶ 20	Tip holder MOG, M8	342P008111	80	Cable lug, flat	375P000023
21	Tip holder MOG, M10	342P010111	81	Insulated connector, male, round	375P000004
Gas nozzles					
▶ 40	Ceramic gas nozzle	401P201404	82	Insulated connector, female, round	375P000003
Spare parts					
50	Torch neck MOG 70, 30°	111P101015	83	Hex nut M14x1	700P002046
60	Handle, blue, cpl.	380P220412			
-	Handle, blue, cpl., (for TBi MOG 50 Z, MOG 70 Z)	380P220413			
62	Cross recessed screw M3.5x14	100P008413			
63	Trigger, red, 2 poles	385P021016			
64	Heat shield, cpl.	381P101002			
65	Housing for rocker switch (TBi MOG 50 Z, MOG 70 Z)	111P102013			
66	Rocker switch (for TBi MOG 50 Z, MOG 70 Z)	385P133010			
70	Bushing	111P102022			
71	Clamp	111P102023			
72	Special set screw M4x18	111P102026			
74	TBi-Flex coaxial cable 70 qmm, for clamping	357P70S2_0*			
75	Cable support 3 parts cpl. with spring	701P101071			
Wire guides					
▶ 100	Liner w/o insulation (x.40 m) for wire 1.6-2.0	322P2863_4*			
100	Liner w/o insulation (x.40 m) for wire 1.6-2.4	322P3570_4*			
100	Liner w/o insulation (x.40 m) for wire 2.4-3.2	322P4570_4*			

Accessories

-	Allen key SW3	391P000035
---	---------------	------------

Please note

These liners can only be installed in conjunction with tip holder M10 (342P010111).

▶ = Standard equipment

* At the blank, please insert suitable information for torch length or wire diameter, e.g. 08 for 0.8 mm or 3 for 3 m.

© 2011 TBi Industries GmbH. All rights reserved. Subject to change without notice. Warranty only when using original TBi consumables and spare parts. Excerpts and reprints not permitted. Nr. DOKP116022, 11/2011.

TBi Industries GmbH
Ruhberg 14
D-35463 Fernwald-Steinbach
P.O. Box 67
D-35461 Fernwald-Steinbach

Tel. + 49 6404 9171-0
Fax. + 49 6404 9171-40
Internet: www.tbi-industries.com
E-mail: info@tbi-industries.com