



TBi MOG 50 Welding Torch for self-shielded flux cored wires

for wires up to 2.4 mm

easily rotatable and exchangeable necks

attractively priced consumables

Ordering information

TBi MOG 50	cable assembly w/o torch neck, Euro-connector	111P3423_0*
TBi MOG 50 Z	as above, with addtl. rocker switch	111P3Z23_0*

Please order the required torch neck and consumables separately according to the part list on page 2.

* At the blank, please insert 3, 4 or 5 for a torch length of 3, 4 or 5 m.

Technical data

Handheld welding torch TBi MOG 50

Rating at 60% duty cycle (10 min. cycle)	330 A
Cooling method	air cooled
Wire diameter	1.0 – 2.4 mm
Technical specification	according to IEC 60974-7
Weight with 1.5m cable	2.00 kg
Connection	Euro-Central connector, other connectors (e.g. CLOOS®, ESAB®, Lincoln®) available upon request.

Torch rating will be reduced when using pulsed-arc power sources. Special torch necks and custom lengths of the coaxial cable are available upon request.

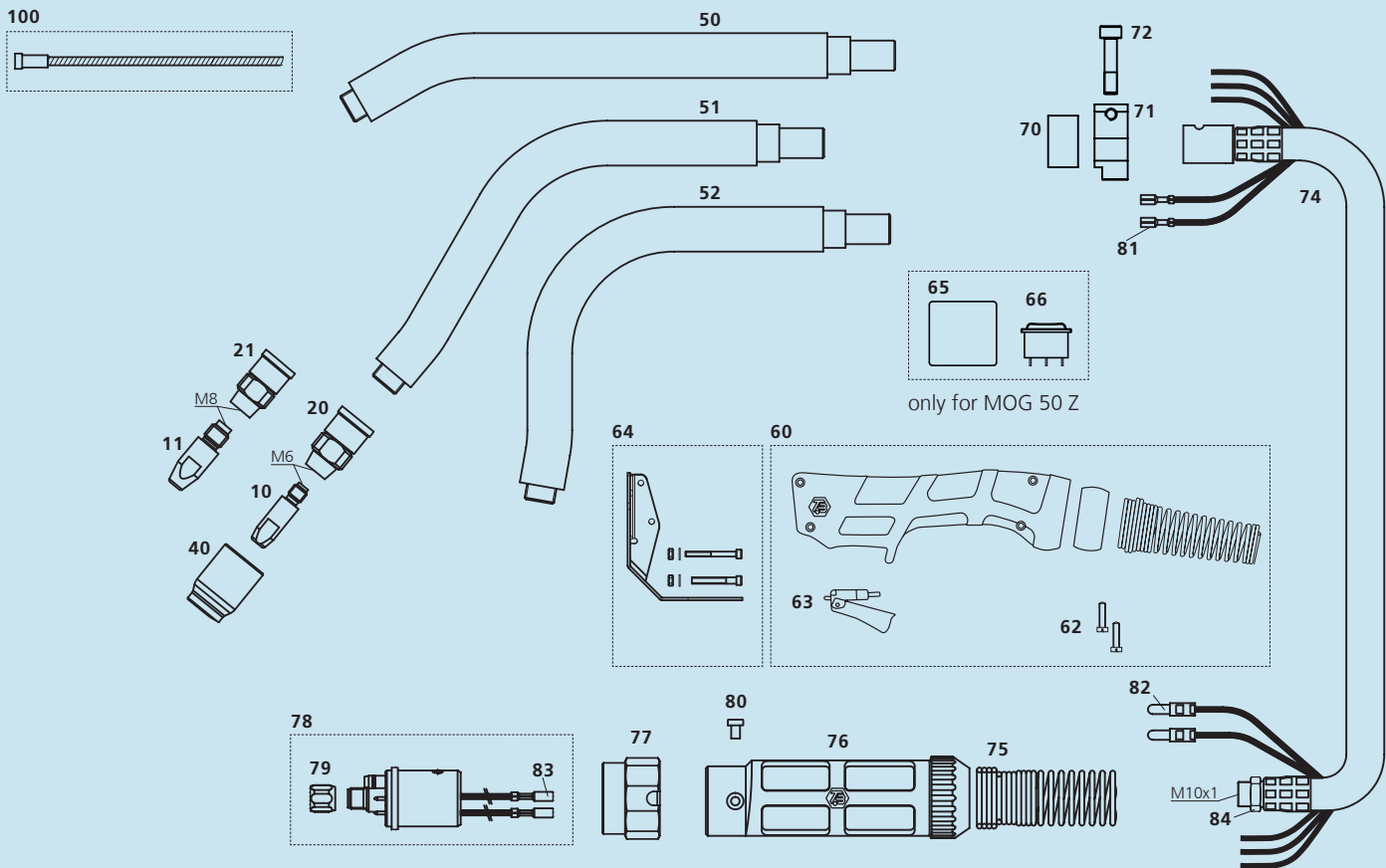

Pos.	Description	Part. No.	Pos.	Description	Part. No.
Contact tips					
10	Contact tip M6x28, ECu	340P__1069*	77	Adaptor nut	701P001013
▶ 10	Contact tip M6x28, CuCrZr	340P__3069*	78	Central adaptor ESG cpl., 2 poles, moveable pins	701P001048
11	Contact tip M8x30, ECu	340P__1262*	79	Sleeve nut M10x1	701P002005
11	Contact tip M8x30, CuCrZr	340P__3262*	80	Slotted screw M4x6	100P008401
Tip holders					
▶ 20	Tip holder MOG 50, M6	342P006111	81	Cable lug, flat	375P000023
21	Tip holder MOG 50, M8	342P008111	82	Insulated connector, male, round	375P000004
Gas nozzles					
▶ 40	Ceramic gas nozzle	401P201404	83	Insulated connector, female, round	375P000003
Spare parts					
50	Torch neck MOG 50, 30°	111P101010	84	Hex nut M10x1	101P002005
51	Torch neck MOG 50, 60°	111P101011	Wire guides		
52	Torch neck MOG 50, 90°	111P101012	▶ 100	Liner w/o insulation (x.40 m) for wire 1.0-1.2	322P2045_4*
60	Handle, blue, cpl.	380P220412	100	Liner w/o insulation (x.40 m) for wire 1.4-1.6	322P2545_4*
-	Handle, blue, cpl., (for TBi MOG 50 Z, MOG 70 Z)	380P220413	100	Liner w/o insulation (x.40 m) for wire 2.0-2.4	322P3549_4*
62	Cross recessed screw M3.5x14	100P008413	Accessories		
63	Trigger, red, 2 poles	385P021016	-	Allen key SW3	391P000035
64	Heat shield	381P101002			
65	Housing for rocker switch (TBi MOG 50 Z, MOG 70 Z)	111P102013			
66	Rocker switch (for TBi MOG 50 Z, MOG 70 Z)	385P133010			
70	Bushing	111P102022			
71	Clamp	111P102023			
72	Special set screw M4x18	111P102026			
74	TBi-Flex coaxial cable 50 qmm, for clamping	357P50S1_0*			
75	Spring support small 16-50 sqmm	600P102099			
76	Cable support cpl. (2 pcs.)	701P001045			
-	Cable support cpl. (2 pcs., for TBi MOG 50 Z)	701P101074			

▶ = Standard equipment

* At the blank, please insert suitable information for torch length or wire diameter, e.g. 08 for 0.8 mm or 3 for 3 m.

© 2010 TBI Industries GmbH. All rights reserved. Subject to change without notice. Warranty only when using original TBI consumables and spare parts. Excerpts and reprints not permitted. Nr. DOKP116012, 12/2010.

TBI Industries GmbH
 Ruhberg 14
 D-35463 Fernwald-Steinbach
 P.O. Box 67
 D-35461 Fernwald-Steinbach

Tel. + 49 6404 9171-0
 Fax. + 49 6404 9171-40
 Internet: www.tbi-industries.com
 E-mail: info@tbi-industries.com